

This drawing is valid for commercial purposes only and must not be copied, disclosed or used without our permission

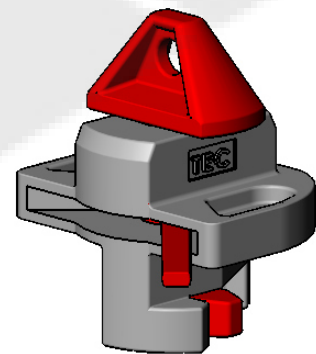

Material:	Ductile Iron (housing)		Drop forged (cone)	
Weight:	5 kg			
SWL Tension	250 kN	SWL Shear	210 kN	
BL Tension	500 kN	BL Shear	420 kN	

SALADA INDUSTRIES FOR METAL
 +966 50 016 5914
www.salada.sa
hello@salada.sa

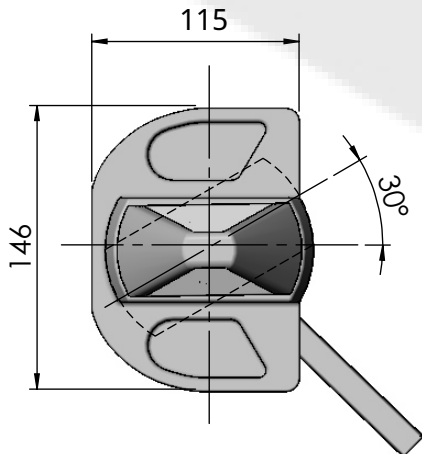
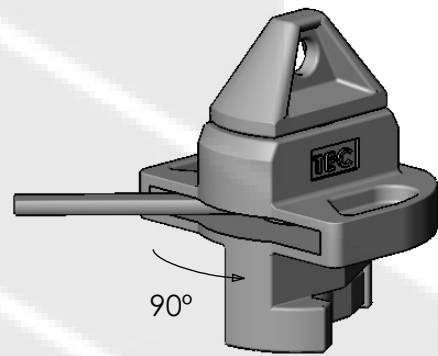
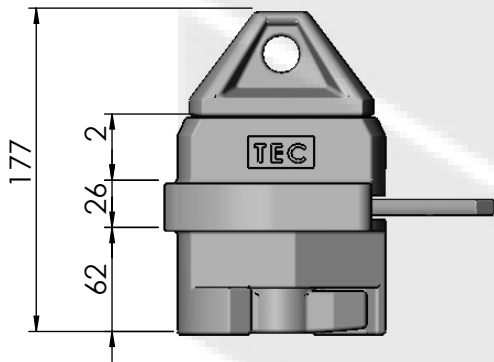
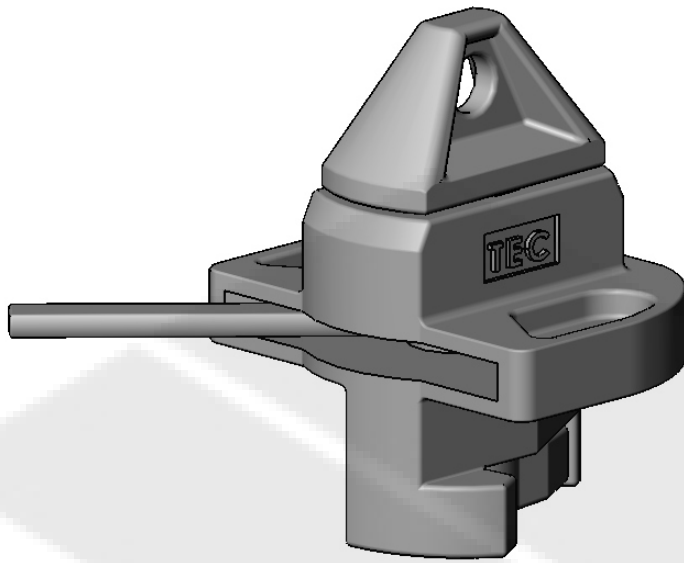

Description:

**TURNFOOT
 TWISTLOCK**

Reference:

CI-21-1R